

Measure the Acute Angle

Name: _____ Class: _____

Measure the size of each acute angle.

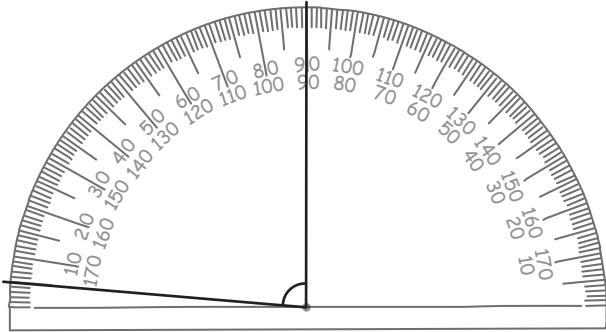

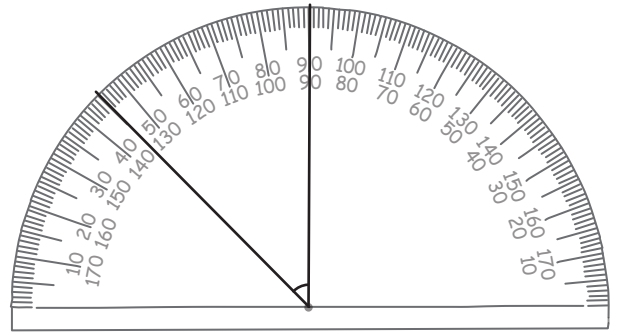

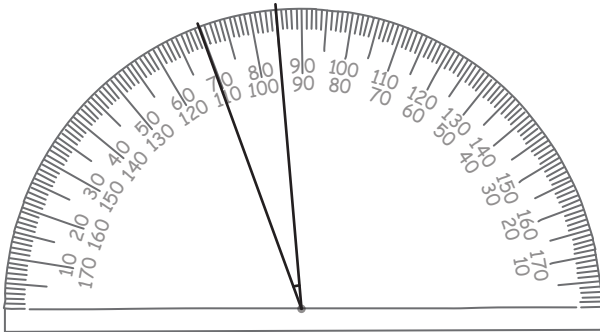

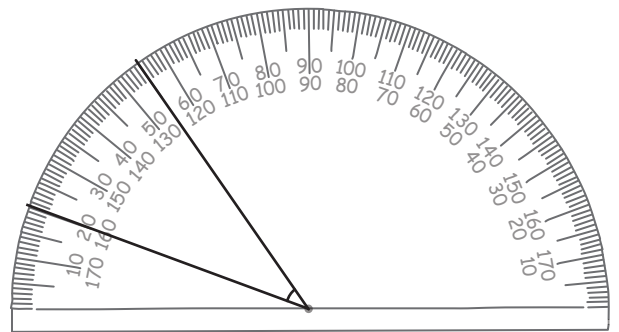

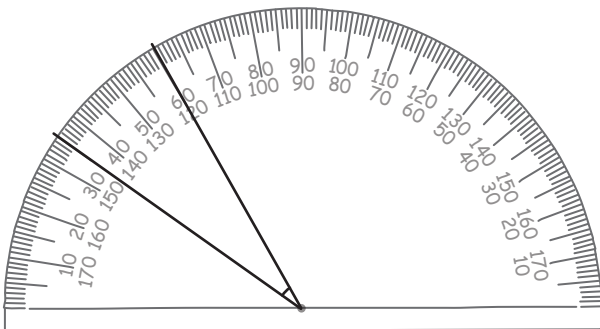

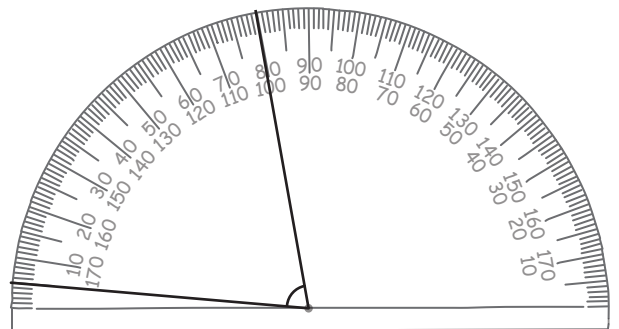

Answers

Measure the size of each acute angle.

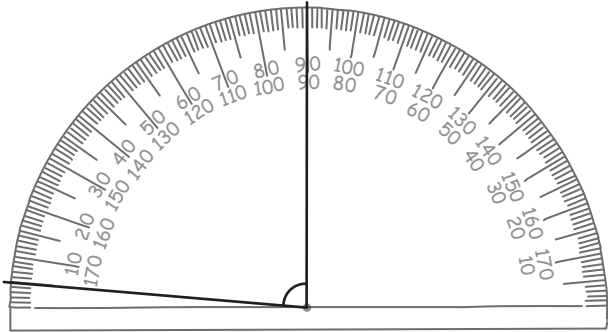

$\angle 85^\circ$

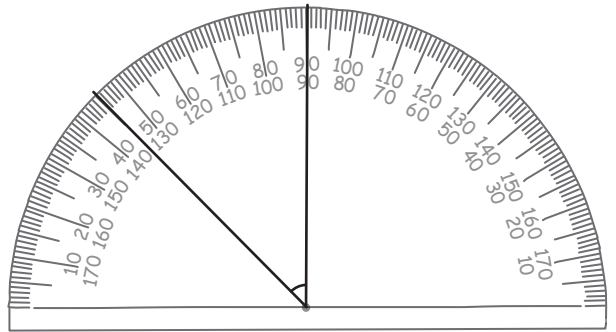

$\angle 45^\circ$

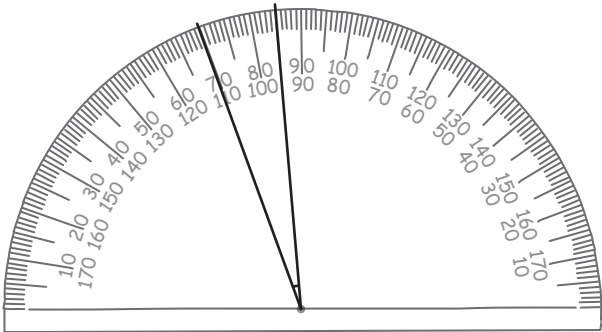

$\angle 15^\circ$

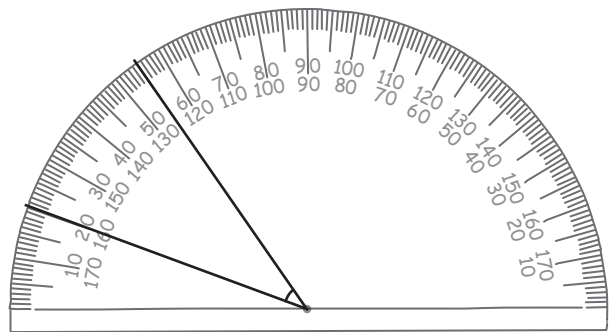

$\angle 35^\circ$

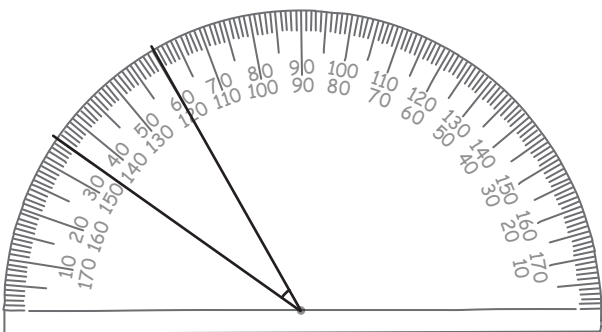

$\angle 25^\circ$

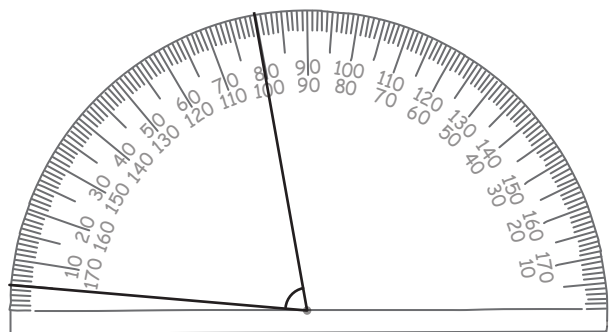

$\angle 75^\circ$